



Photo: Zorro



***A Bench with a Twist* for Chumleigh Gardens** **Bruno Taylor**

Description

This is a public park bench that encourages playful and social interactions between users. It is sprung and offers a degree of movement and 'bounce' to engage people and bring them together under a shared playful experience.

Social interactions are important in a democratic society and provide an opportunity to debate and discuss meaningful topics. Many public spaces do little to encourage social interactions and are often discouraging of playful behaviour outside a playground. A public realm which offers more opportunities for playful and social interactions and a greater cohesion between different people from young to old is much needed.

Public furniture that brings different groups of people together through a shared experience can generate interesting topics of conversations. Perhaps the need to remove all potential causes of conflict between groups is not the best approach and a more playful and responsive environment can play a role in more democratic and public debate.

The Bench with a Twist goes towards creating a more friendly public realm and is itself a topic of debate as to how play can be integrated better in public space.

The bench ends are fabricated from high carbon steel (or spring steel) and powder coated to give an extremely durable finish. The steel is bent into shape while it is in a soft annealed condition and then heat treated to give it a high tensile strength.

Thought and consideration has gone into the safety and potential misuse of the bench, therefore it has been designed to support and withstand the weight of three large men without deforming. The design has gone through computer generated stress analysis. However, the production of this bench is dependant on the testing of a prototype to ensure its safety and support accurate risk management. The amount of spring in the bench is controlled by the thickness of the metal and will offer subtle playful responses rather than extreme movement. The wood is treated teak similar to many of the park benches currently in use.

The Bench with a Twist can be located in many different spots within the gardens – rocking gently in front of the mosaic decorations in the Islamic area or the more grassy lawn by the café perhaps.



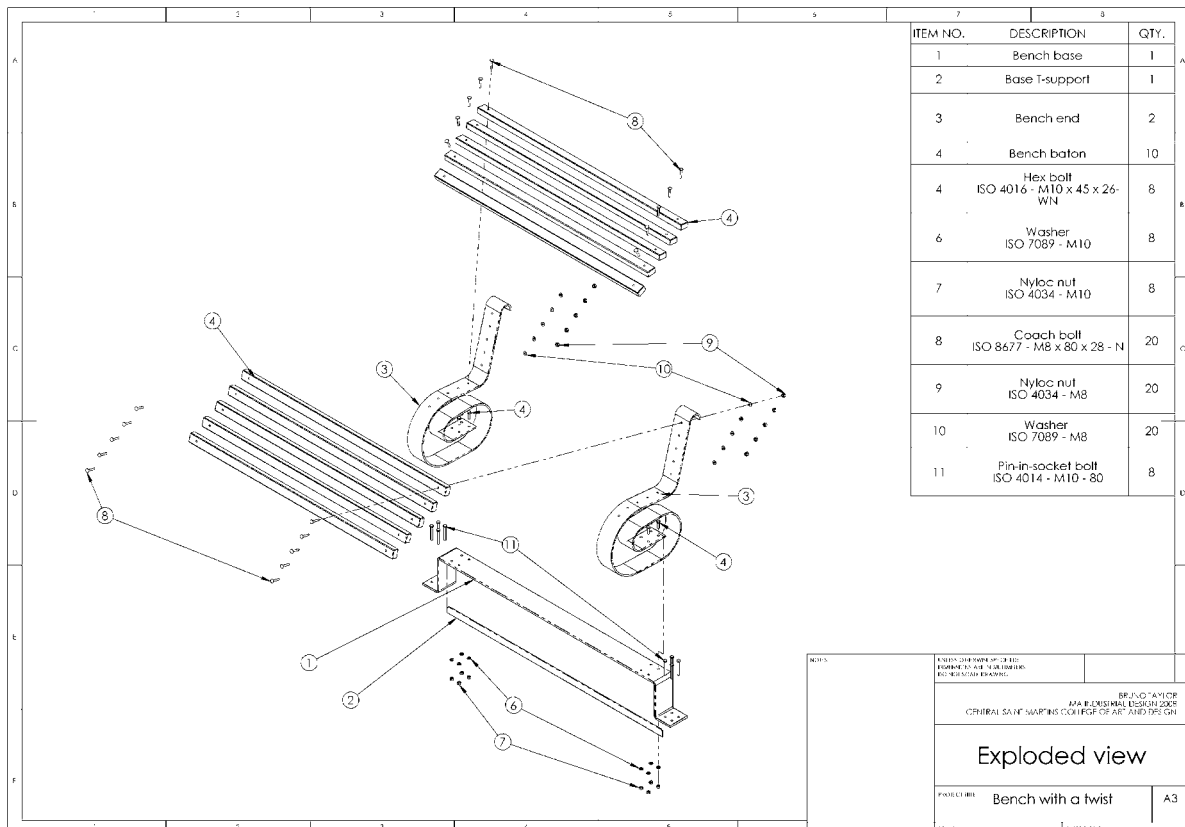
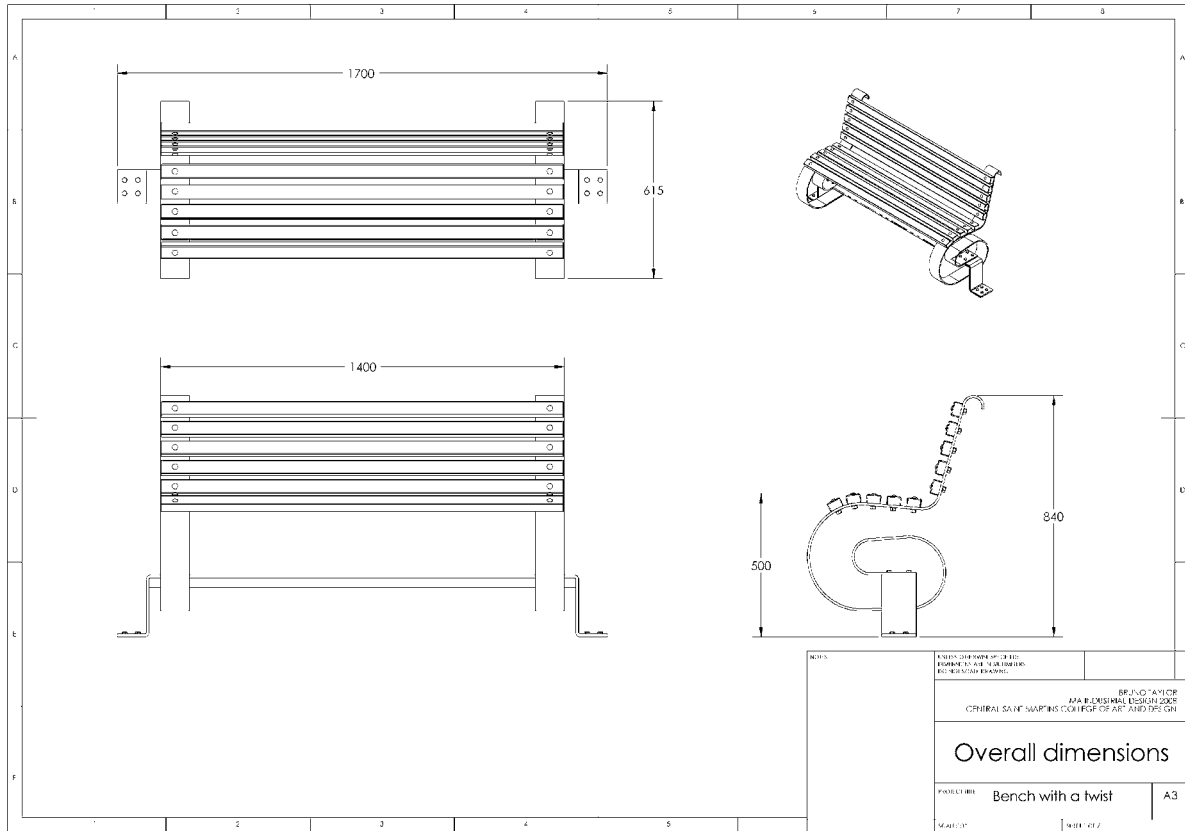

Ground Installation

The bench is secured by four sleeve fixings which are secured with a chemical anchor into concrete foundations. Bolts are tamper resistant

